

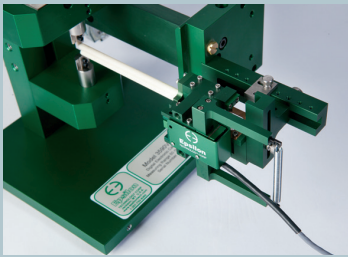

High temperature COD gages for use in split type materials testing furnaces with a slot for the ceramic rods. Water-cooled and furnace bracket mounted, these extensometers are for use to 1200 °C (2200 °F). The high temperature option allows use to 1600 °C (2900 °F). They are specifically designed for fracture mechanics testing.

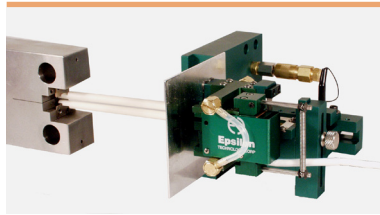

Model 3548COD with no heat shields mounted to a Model 3590VHR calibrator



Model 3548COD mounted to a compact tension specimen

These COD gages mount on a water-cooled bracket, which is mounted on the furnace side cut-out or with optional load frame support brackets. The standard temperature version (to 1200 °C) is supplied with high purity alumina rods. The high temperature option is furnished with alpha grade silicon carbide rods. Rods are made to order to the length required for your furnace. Mounting brackets may be integrated with the furnace cut-out. Epsilon can also provide optional load frame mounting brackets to fit your test frame. Contact edges on the test sample should be somewhat rounded (not sharp knife edges) for best performance with this model.

The Model 3548COD extensometers are strain gaged devices, making them compatible with any electronics designed for strain gaged transducers. Most often they are connected to a test machine controller. The signal conditioning electronics for the extensometer is typically included with the test machine controller or may often be added. In this case the extensometer is shipped with the proper connector and wiring to plug directly into the electronics. For systems lacking the required electronics, Epsilon can provide a variety of solutions, allowing the extensometer output to be connected to data acquisition boards, chart recorders or other equipment.

See the electronics section of this catalog for available signal conditioners and strain meters.

Features

- **May be left on through specimen failure.**
- Full bridge, 350 ohm strain gaged design for compatibility with nearly any test system.
- All standard units meet existing ASTM E1820 requirements for accuracy. A test certificate is included.
- For KIC/JIC testing, maximum accuracy is achieved with the smallest measuring range and the largest gauge length that will perform the test.
- All units come with either high purity alumina ceramic rods (1200 °C) or alpha grade silicon carbide rods (1600 °C).
- Rugged, dual flexure design for strength and improved performance.
- Includes high quality foam lined case and a spare set of ceramic rods.

SPECIFICATIONS

Excitation: 5 to 10 VDC recommended, 12 VDC or VAC max.

Output: 2 to 4 mV/V nominal, depending on model

Linearity: ≤0.15% of full scale measuring range, depending on model

Temperature Range: Standard (-ST) is to 1200 °C (2200 °F), optional (-HT) 1600 °C (2900 °F)

Cable: Integral, ultra-flexible cable, 2.5 m (8 ft) standard

Operating Force: <30 g typical

OPTIONS

Load frame mounting brackets

High temperature option (-HT suffix) for use to 1600 °C

Connectors to interface to nearly any brand test equipment

Shunt calibration module (see page 120)



ORDERING INFORMATION

Model 3548COD Available Versions: ANY combination of gauge length, measuring range and temperature range listed below is available, except as noted. *Ceramic rod lengths are made to fit furnaces as required. Please provide furnace dimensions at the time of order. Other configurations may be available with special order; please contact Epsilon to discuss your requirements.*

Gauge Length		Measuring Range	
METRIC		METRIC	
-005M	5.0 mm	-025M	+2.5 mm
-008M	8.0 mm	-040M	+4.0 mm
-010M	10.0 mm	-070M	+7.0 mm
-012M	12.0 mm	-100M	+10.0 mm
-020M ¹	20.0 mm	-120M	+12.0 mm
U.S.A.		U.S.A.	
-0020	0.200"	-100T	+0.100"
-0030	0.300"	-150T	+0.150"
-0040	0.400"	-200T	+0.200"
-0047	0.475"	-250T	+0.250"
-0050	0.500"	-500T	+0.500"

Model Number 3548COD- _____ - _____ - _____

Temperature Range	
-ST	Ambient to 1200 °C (Ambient to 2200 °F)
-HT	Ambient to 1600 °C (Ambient to 2900 °F)

¹ Only available in small measuring ranges (rod length dependent).

Example: 3548COD-0050-200T-HT: 0.500 inch compressed gauge length, +0.20 inch measuring range, high temperature option (room temperature to 1600 °C (2900 °F))

Visit our website at www.epsilontech.com
Contact us for your special testing requirements.

Model 2050 Constant Temperature Re-Circulation Bath

This bath provides the controlled temperature flow for water-cooled extensometers. Capable of cooling or heating the water, temperature is maintained within 0.1 °C. These units are ideal for obtaining the maximum stability of any water-cooled extensometer.

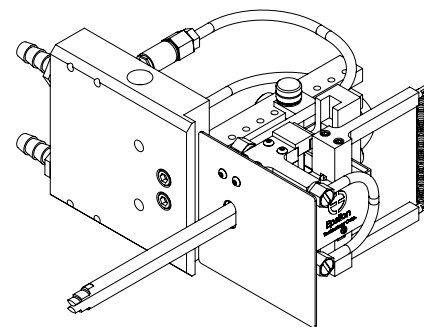

MODEL 3548COD EXAMPLE