

Designed for accurate measurement of small diametral strains such as those required to determine Poisson's ratio of rock, concrete and asphalt samples. The units are designed to be used in conjunction with the Model 3542RA axial averaging extensometer.



Model 3975 extensometer

Self-supporting on the test sample, these extensometers will work on standard sized diameter samples, but special configurations are available upon request. They are designed for use in testing for Poisson's ratio and for applications where accurate diametral measurements with low strains are required.

The Model 3975 is the best choice for small diametral strains in large compression samples. Epsilon's circumferential extensometer, the Model 3544, is recommended for large strain measurements. These units are easily attached to the sample, and rounded contact edges maintain the position on the specimen.

The Model 3975 extensometers are strain gaged devices, making them compatible with any electronics designed for strain gaged transducers. Most often they are connected to a test machine controller. The signal conditioning electronics for the extensometer is typically included with the test machine controller or may often be added. In this case the extensometer is shipped with the proper connector and wiring to plug directly into the electronics. For systems lacking the required electronics, Epsilon can provide a variety of solutions, allowing the extensometer output to be connected to data acquisition boards, chart recorders or other equipment.

See the electronics section of this catalog for available signal conditioners and strain meters.

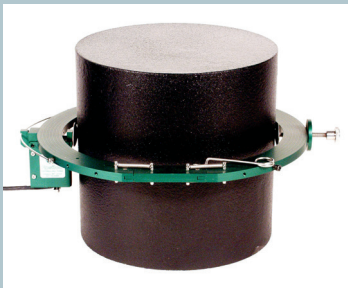

Model 3975 extensometer



Model 3975 extensometer

Features

- Full bridge, 350 ohm strain gaged design for compatibility with nearly any test system.
- All standard units have linearity readings of 0.20% or better.
- Includes high quality foam lined case.
- Rugged, dual flexure design for improved performance.
- Easy mounting, attaches with integral springs.
- Self-supporting on the specimen.

SPECIFICATIONS

Excitation: 5 to 10 VDC recommended, 12 VDC or VAC max.

Output: 2 to 4 mV/V nominal, depending on model

Linearity: $\leq 0.20\%$ of full scale measuring range, depending on model

Temperature Range: Standard (-ST) is $-40\text{ }^{\circ}\text{C}$ to $+100\text{ }^{\circ}\text{C}$ ($-40\text{ }^{\circ}\text{F}$ to $+210\text{ }^{\circ}\text{F}$)
Optional (-LHT) is $-270\text{ }^{\circ}\text{C}$ to $+200\text{ }^{\circ}\text{C}$ ($-454\text{ }^{\circ}\text{F}$ to $400\text{ }^{\circ}\text{F}$)

Cable: Integral, ultra-flexible cable, 2.5 m (8 ft) standard

OPTIONS

Additional frames for larger or smaller diameter samples
Connectors to interface to nearly any brand test equipment
Shunt calibration module (see page 120)



ORDERING INFORMATION

Model 3975 Available Versions: Consult factory for additional ranges. Other configurations may be available with special order; please contact Epsilon to discuss your requirements.

Measuring Range	
METRIC	
-076M	+0.76 mm
-150M	+1.50 mm
-200M	+2.00 mm
U.S.A.	
-0003	+0.030"
-0006	+0.060"
-0008	+0.080"

Model Number 3975- _____ - _____

Temperature Range	
-LT	$-270\text{ }^{\circ}\text{C}$ to $100\text{ }^{\circ}\text{C}$ ($-454\text{ }^{\circ}\text{F}$ to $210\text{ }^{\circ}\text{F}$)
-ST	$-40\text{ }^{\circ}\text{C}$ to $100\text{ }^{\circ}\text{C}$ ($-40\text{ }^{\circ}\text{F}$ to $210\text{ }^{\circ}\text{F}$)
-HT1	$-40\text{ }^{\circ}\text{C}$ to $150\text{ }^{\circ}\text{C}$ ($-40\text{ }^{\circ}\text{F}$ to $300\text{ }^{\circ}\text{F}$)
-HT2	$-40\text{ }^{\circ}\text{C}$ to $200\text{ }^{\circ}\text{C}$ ($-40\text{ }^{\circ}\text{F}$ to $400\text{ }^{\circ}\text{F}$)
-LHT	$-270\text{ }^{\circ}\text{C}$ to $200\text{ }^{\circ}\text{C}$ ($-454\text{ }^{\circ}\text{F}$ to $400\text{ }^{\circ}\text{F}$)

Example: 3975-0008-ST: +0.080 inches measuring range, standard temperature option ($-40\text{ }^{\circ}\text{C}$ to $100\text{ }^{\circ}\text{C}$)

Visit our website at www.epsilontech.com
Contact us for your special testing requirements.

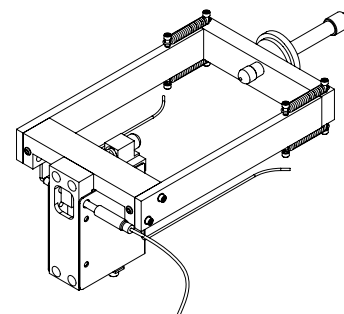

MODEL 3975 EXAMPLE